

233/2

— **CHEMISTRY** —

Paper 2



(THEORY)

Mar. 2021 – 2 hours

119

Name Index Number

Candidate's Signature Date

Instructions to candidates

- (a) Write your name and index number in the spaces provided above.
- (b) Sign and write the date of examination in the spaces provided above.
- (c) Answer **all** the questions in the spaces provided in this booklet.
- (d) **Non-programmable** silent electronic calculators and KNEC mathematical tables may be used.
- (e) All working **must** be clearly shown where necessary.
- (f) **This paper consists of 15 printed pages.**
- (g) **Candidates should check the question paper to ascertain that all the pages are printed as indicated and that no questions are missing.**
- (h) **Candidates should answer the questions in English.**

For Examiner's Use Only

Question	Maximum Score	Candidate's Score
1	13	
2	14	
3	13	
4	12	
5	14	
6	14	
Total Score	80	

2010



1. Crude oil is a mixture of hydrocarbons which are separated by fractional distillation. One of the components obtained contains an alkane **A**, with eleven carbon atoms. (1 mark)

(a) Write the molecular formula of **A**.

.....

.....

.....

(b) Pentane can be obtained from compound **A** as shown.



(i) Give the name of this conversion process. (1 mark)

.....

(ii) State the conditions used in this process. (1 mark)

.....

.....

(iii) Give the name of compound **B**. (1 mark)

.....

(c) Draw and name **two** isomers of pentane. (4 marks)

Isomer 1

Structure

Name

.....

.....

.....

.....

.....

.....

Isomer 2	Structure	Name
(d) Incomplete combustion of pentane may result in air pollution. Write an equation to illustrate this combustion. (1 mark)		
(e) The main component in natural gas is methane. Describe how methane in natural gas is formed. (2 marks)		
(f) In the laboratory, methane can be prepared from salts of alkanolic acids. Describe how methane is prepared from sodium ethanoate. (2 marks)		

(1 mark)

2. (a) (i) State what is meant by the term 'dynamic equilibrium'.

.....

.....

.....

.....

.....

- (ii) Dichromate(VI) ions are orange in colour while chromate(VI) ions are yellow. Consider the following equilibrium.

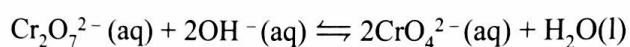

State and explain the observation that will be made if sulphuric(VI) acid is added to the mixture. (2 marks)

.....

.....

.....

.....

.....

- (b) One of the reactions in the manufacture of nitric(V) acid involves catalytic oxidation of ammonia as shown in the equation.

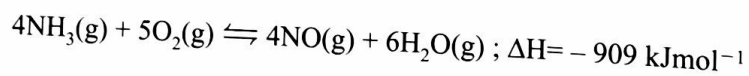

The reaction is carried out at a pressure of 10 atmospheres and a temperature of 900 °C

- (i) Other than nitric(V) acid, name another product that is formed. (1 mark)

.....

(ii) State and explain the effect on the position of equilibrium if the reaction is carried out:

(2 marks)

I. at 10 atmospheres pressure and 450 °C;

.....
.....
.....
.....

II. at 900 °C and 20 atmospheres pressure;

(2 marks)

.....
.....
.....
.....

III. in the absence of a catalyst.

(1 mark)

.....
.....

(c) State and explain the effect on the rate of the reaction if the reaction is carried out at 10 atmospheres and 450 °C.

(2 marks)

.....
.....
.....
.....
.....



- (d) A factory uses 100 kg of ammonia each day to produce 160 kg of nitrogen(II) oxide. (3 marks)
Calculate the percentage yield of nitrogen(II) oxide.

.....

.....

.....

.....

.....

3. (a) One of the ores of iron is haematite, Fe_2O_3 . Give the name and formula of **two** other ores of iron. (2 marks)

Name	Formula
------	---------

- (i)
- (ii)

- (b) In a certain factory, iron is extracted from the haematite ore using the blast furnace as shown in **Figure 1**. The other raw materials are coke, limestone and air. The melting and boiling points of iron are 1535°C and 3000°C , respectively.

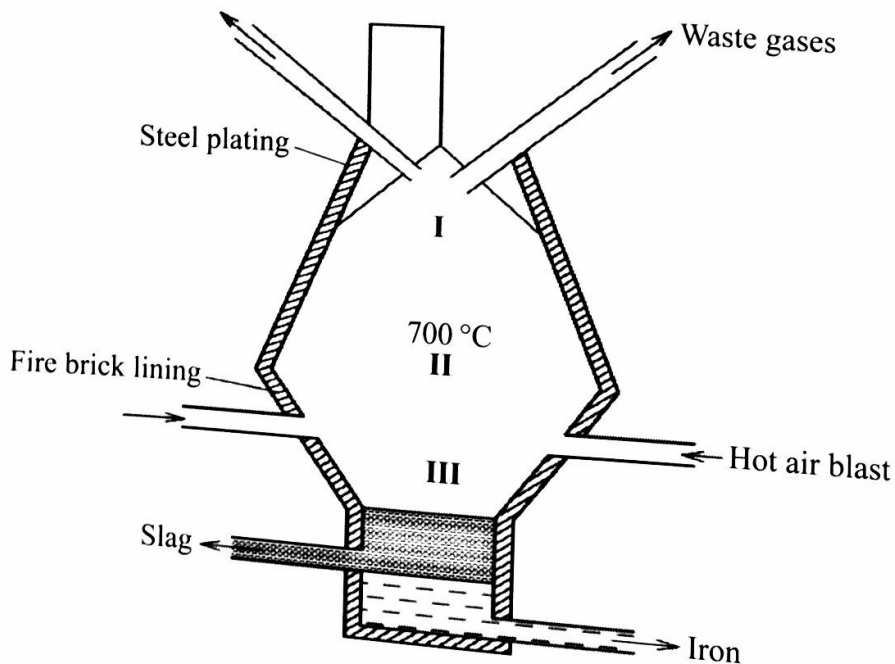

Figure 1

- (i) State how the temperature in region **I** compares with that in region **II**. Give a reason. (1 mark)

.....

.....

.....

.....

- (ii) The main reducing agent in the furnace is carbon(II) oxide formed by the reaction:

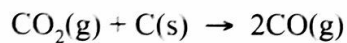

Write **two** equations to show how carbon(IV) oxide is formed in the furnace. (2 marks)

I.

.....

II.

.....

- (iii) Suggest a value for the temperature in region **III**. Give a reason. (2 marks)

.....

.....

.....

.....

- (iv) Name the main component in the slag. (1 mark)

.....

- (v) State **one** role that slag plays in the blast furnace. (1 mark)

.....

.....

(vi) The iron produced in the blast furnace is brittle due to presence of impurities. (1 mark)

I. Name the main impurity in this iron.

.....

II. State one use of this iron. (1 mark)

.....

(vii) Recycling is one method used to reduce production costs. State and explain the by products that can be recycled in this factory. (2 marks)

.....

4. Table 1 shows the elements in period 3 of the periodic table. Study it and answer the questions that follow.

Table 1

Element	Na	Mg	Al	Si	P	S	Cl	Ar
---------	----	----	----	----	---	---	----	----

(a) Write the formulae of **two** oxides, for each of the following:

(i) sodium: Oxide I Oxide II (1 mark)

(ii) chlorine Oxide I Oxide II (1 mark)

(b) The products of the reaction between phosphorus and chlorine depend on the conditions used. Write the equation for the reaction when chlorine reacts with excess phosphorus. (1 mark)

.....



(c) Identify the element with the highest electrical conductivity. Give a reason. (2 marks)

.....
.....
.....

(d) Describe an experiment that can be used to illustrate the variations in reaction of sodium, magnesium and aluminium with water. (3 marks)

.....
.....
.....
.....
.....

119

(e) State and explain the differences in the melting points of:

(i) chlorine and argon. (2 marks)

.....
.....
.....
.....
.....

(ii) magnesium oxide and silicon(IV) oxide. (2 marks)

.....
.....
.....
.....
.....

2010



5. Table 2 gives standard reduction potentials for some half cells.

Table 2

Half cell	Half cell equation	E^{\ominus} / V
I	$\text{Fe}^{3+}(\text{aq}) + \text{e} \rightarrow \text{Fe}^{2+}(\text{aq})$	+ 0.77
II	$\text{K}^{+}(\text{aq}) + \text{e} \rightarrow \text{K}(\text{s})$	- 2.92
III	$\text{Ag}^{+}(\text{aq}) + \text{e} \rightarrow \text{Ag}(\text{s})$	+ 0.80
IV	$\text{Pb}^{2+}(\text{aq}) + 2\text{e} \rightarrow \text{Pb}(\text{s})$	- 0.13
V	$\text{I}_2(\text{aq}) + 2\text{e} \rightarrow 2\text{I}^{-}(\text{aq})$	+ 0.54

- (a) State the standard conditions of an electrochemical cell. (2 marks)

.....

.....

.....

.....

.....

- (b) An electrochemical cell was constructed using half-cells III and IV.

- (i) Complete Figure 2 by labelling the parts of the cells indicated as $\text{A}_1 - \text{A}_4$. (2 marks)

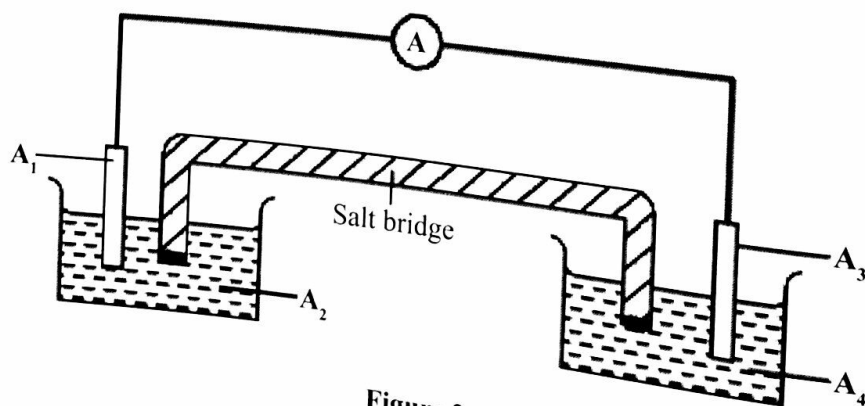

Figure 2

- A₁
- A₂
- A₃
- A₄

(ii) Write an equation for the cell reaction and calculate the e.m.f. of the cell.

Equation (1 mark)

.....

.....

e.m.f. (1 mark)

.....

.....

(iii) The salt bridge helps in completing the circuit. Explain why a saturated solution of potassium chloride is **not** suitable for use in the salt bridge in this electrochemical cell.

(1 mark)

.....

.....

(c) State why it is **not** possible to construct a similar electrochemical cell using half-cells **II** and **III**. (1 mark)

.....

.....

.....

- (d) State and explain the observations made when aqueous potassium iodide is added to aqueous iron(III) sulphate. (2 marks)

.....

.....

.....

.....

- (e) Acidified potassium dichromate(VI) and acidified potassium manganate(VII) may be used in determining concentration of Fe^{2+} ions in a sample. If acidified potassium dichromate(VI) is used, an indicator is added to determine the end point but for acidified potassium manganate(VII), no indicator is added.

- (i) Explain why it is **not** necessary to use an indicator when acidified potassium manganate(VII) is used. (1 mark)

.....

.....

.....

- (ii) An alloy containing iron was dissolved in an acid and the total volume made up to 250 cm^3 . 25.0 cm^3 of this solution required 18.0 cm^3 of 0.15 M acidified potassium dichromate(VI) to react completely. The equation for the reaction is:

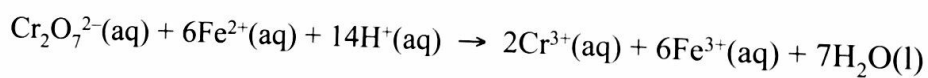

Calculate the mass of iron in the alloy ($\text{Fe} = 56.0$).

(3 marks)

.....

.....

.....

.....

.....

.....

.....

.....

.....

.....



6. (a) Water containing hydrogen carbonate, HCO_3^- , and calcium Ca^{2+} ions, is said to be hard water.
- (i) Describe **one** way in which HCO_3^- ions get into river water. (1 mark)
-
-
- (ii) Explain the disadvantage of using this type of water in boilers. (2 marks)
-
-
-
-
- (b) Analysis of a river water sample showed the presence of the following ions:
 Ca^{2+} , Na^+ , Cl^- , NO_3^- .
- (i) Name the type of water hardness present in the sample. (1 mark)
-
- (ii) Describe **one** precipitation method that can be used to soften the water. (2 marks)
-
-
-
-

- (iii) The water sample was passed through a resin as shown in **Figure 3**.

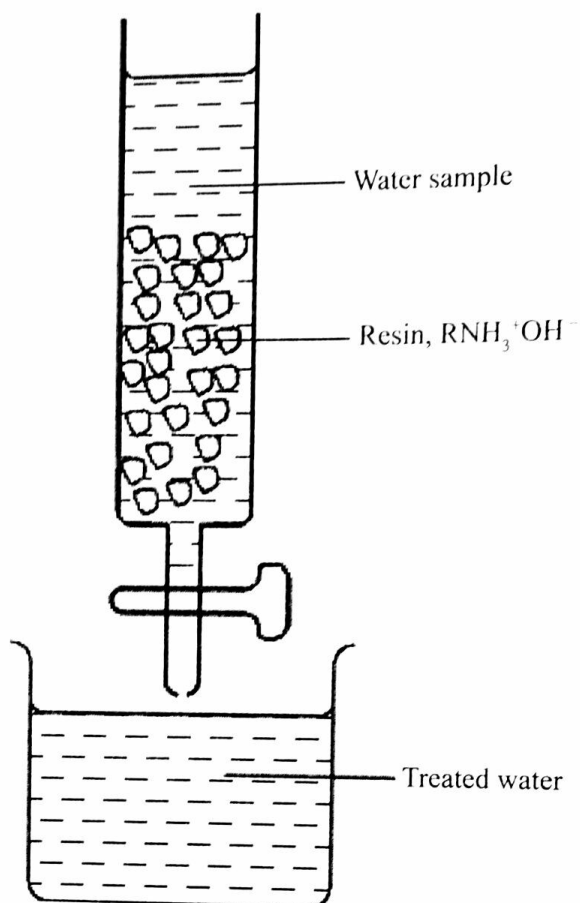
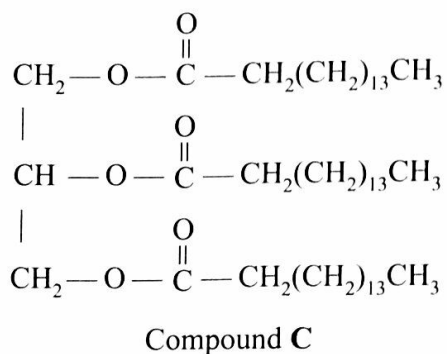

Figure 3

- I. Write an equation for a reaction that took place in the column. (1 mark)
-
- II. Complete treatment of the water sample required passing it through another resin. Give the formula of this resin. (1 mark)
-
- III. Explain why a river water sample that has been treated using resins may still require boiling to make it safe for drinking. (2 marks)
-
-
-
-

- (c) Compound **C** was used to prepare a potassium soap.



- (i) Give the formula of the potassium soap obtained. (1 mark)

.....

- (ii) State **one** difference in the properties of potassium and sodium soaps. (1 mark)

.....

- (d) A soapless detergent has the formula
 $\text{CH}_3(\text{CH}_2)_{10}\text{CH}_2\text{OSO}_3\text{Na}$

With reference to this formula, identify the hydrophobic and the hydrophilic parts of the detergent.

Hydrophobic (1 mark)

.....

Hydrophilic (1 mark)

.....

THIS IS THE LAST PRINTED PAGE